

Table of Contents

General Information.....	2
Hydraulic & Electrical Operational Diagrams.....	8
Hydraulic & Electrical Installation.....	17
Parts List.....	23
Troubleshooting.....	28

M673010-01L06E (old version) Operating Information



GENERAL INFORMATION

The M673F hydraulic power unit is specially designed for the snowplow application. This unit has a 3 way/4 way (single/double acting) function. Valves are protected by an ABS plastic cover from environment and abuse.

Warranty Identification

For purposes of warranty consideration, recording the serial number of the power unit is necessary. This serial number is displayed on a label affixed to the reservoir tube.

General Maintenance

Under normal operating conditions, the M673F should not require servicing during the plowing season, provided periodic post season maintenance has been carried out.

Post Season Maintenance

It is recommended that the hydraulic fluid is changed every season. The replacement fluid recommended is **UNIVIS J13 (HVI 13)** hydraulic fluid. Automatic transmission fluid is not recommended for this system and may lead to aeration of the oil in very cold weather conditions.

Care should be taken that with the lift cylinder fully retracted the oil level in the reservoir is to within 1/2" from the top surface of the cap. Before draining, release pressure in the cylinders by pressing the pressure button on the control box. When draining the hydraulic fluid, the hoses at the cylinders should be disconnected and drained. With the hose disconnected, the cylinders should be collapsed. When refilling the system, it is recommended that the hoses and cylinders be bled by loosening the hydraulic fittings at the cylinders until they leak. Power angle plow repeatedly from side to side until fluid flows steadily from leaking fittings. **Care should be taken in maintaining the fluid level in the reservoir during this operation.**

When the hydraulic system is not used for an extended period of time, such as in the off season, all exposed chrome rod surfaces should be coated with an axle grease.

Electrical System

Frequently problems develop due to an undersized electrical charging and storage system. Generally, the heavier the usage, the heavier the system should be. For a moderately light duty, the battery should not be less than 70 ampere-hours and the alternator should charge at a rate of not less than 60 amperes. For heavy usage and in the case where a number of other devices are run off the battery simultaneously, heavier ratings are strongly recommended. Periodically, and during post season maintenance, make sure the electrical connections are tight and free of corrosion. The terminals may be covered with grease for additional protection from corrosion.

Electric Motor

The 8034 electric motor is a two pole electromagnetic motor, consisting primarily of an armature/commutator, two field coils, four brushes in a brush holder set, and a tubular steel body with cast endcap. Although the motor is grounded through the body, an additional grounding stud is provided on the motor body. The motor must be grounded to the vehicle body with a grounding strap from this stud.

The power unit with this motor is equipped with the 03 pump. This combination of pump and motor offers optimum performance.

The motor should be serviced periodically to insure good performance. Service as follows:

- a) check brush set for wear and replace if necessary,
- b) blow dirt and dust off motor housing and check for shorts, burnt wires or open circuits,
- c) check bearings (bad bearings can cause a motor to make growling noise),
- d) check for excessive "end play" of an armature and add thrust washers as required.

Hydraulic Pump

The hydraulic pump converts mechanical energy transmitted by the prime mover (in this case a 12 volt DC electric motor) into hydraulic energy. The hydraulic energy is due to flow (kinetic energy) and pressure (potential energy). The rate of energy output is expressed in horsepower.

At the inlet, as the gears unmesh, the volume in the cavity increases thereby causing fluid to enter. This fluid is then carried between the gears and the housing to the other side of the gears into the outlet cavity. At this point the gear teeth mesh. The outlet cavity volume decreases, causing fluid to flow into the system. Note that without a load, the pressure at the outlet port is nil.

The pressure at the outlet of the pump is due to external loads placed on the system. These loads can be transmitted through cylinders and linear actuators, In practice, system component, by virtue of orifice and line sizes, offer some resistance to the flow of fluid. This translates into pressure at the outlet of the pump.

Pressure Relief Valve

The pressure relief valve consists of a ball, a retaining spring and a seat. The ball is exposed to the pressure in the outlet line from the pump. This pressure acting on the exposed area of the ball causes a force on the retaining spring. When the pressure is such that the force on the ball exceeds the force in the spring (due to a preset amount of compression) the ball lifts off the seat and the fluid from the outlet of the pump is allowed to flow back to the reservoir. The "standard setting" for the M673F is 2250 psi.

Solenoid Valves

The M673F circuit contains 4 solenoid valves. These are identified as "A", "B", "C", and "D".

Solenoid valve "A", "B", "C" are 2 way/2 position normally closed poppet (check) type valves. The "D" valve is a 4 way/2 position valve of a spool type construction.

A basic solenoid valve consists of a valve cartridge and coil. The valve cartridge is compressed of an armature attached to a valve mechanism. This armature is controlled electrically by way of a coil. The cartridge screws into a modular valve manifold.

The coil consists of a certain length of wire wrapped around a spool and often surrounded by a metal can. When current is put through the coil, magnetic forces are set up causing the armature to be pulled further into the coil. The armature pulls a poppet or spool into its energized position. A coil spring is compressed in this position; hence when the current ceases and the magnetic field has collapsed, this spring pushes the armature back to its de-energized (normal) position.

Solenoid Valve "A"

Valve "A" is a 2way/2position poppet valve that is closed in the de-energized position. When the plow is angled by extending the cylinder connected to C1 (see diagram, figure 1), the cylinder connected to C2 must be allowed to retract. This is accomplished by opening solenoid valve "A".

In its normal de-energized position, valve "A" acts as a check valve preventing the cylinder connected to C2 from collapsing when forces are placed upon it during the plowing operation.

Solenoid Valve "B"

Valve "B" is identical to valve "A". Its purpose in the circuit is to check the oil from the lift cylinder (see diagram, figure 4), thereby holding the plow up when not in use. To lower the plow, this valve must be energized to the open position. This allows fluid from the lift cylinder to return to the reservoir.

Valve "B" is also energized while plowing snow. In this manner, the plow is allowed to "float" and follow the contour of the ground.

Solenoid Valve "C"

The "C" valve is a 2 way/2 position poppet valve. In the normal or de-energized position it is closed, allowing no flow in any direction. In the de-energized state, valve "C" prevents fluid from entering the lift circuit while angling side is being operated. When valve "C" is energized (see diagram, figure 3) and with valve "A" being normally closed, fluid flows to the lift circuit and will cause the lift cylinder to extend. Note that valve "B" is also normally closed.

Solenoid Valve "D"

Solenoid valve "D" is a 4 way/2 position spool valve. In its normal de-energized position, pressurized pump flow is directed through the valve to C1 allowing the cylinder to extend. Valve "A" must be energized simultaneously, thereby allowing fluid from C2 to be returned through it and valve "D" and thence to the reservoir.

When valve "D" is energized (see diagram, figure 2), pressurized fluid flows through valve "A" to the C2 cylinder causing it to extend. Note that valve "A" is not energized as its poppet check type construction does allow flow in one direction, as would be the case with the check valve.

Return flow from C1 passes through a pilot operated check valve and valve "D" back to the reservoir.

Check Valves

The M673F incorporates one check valve and one pilot operated check valve.

Check Valve

A simple check valve allows fluid to flow in one direction only. No fluid can pass through in the opposite direction. A simple check valve is located between the "C" solenoid valve and the lift cylinders (see any diagram, figure 1-4). Fluid can flow from the pump through the check valve into the lift cylinder. However, no flow can occur from the lift cylinder back through this valve.

Pilot Operated Check Valve

A pilot operated check valve (p.o. check valve) allows flow in one direction. The flow path in the opposite direction is closed or checked. This opposite flow path however, can be opened by way of pilot pressure. When the checked flow path is opened, pilot pressure acts on top of a piston which has a pin connected to it at the opposite end. The pressure moves the piston causing the pin to make contact with the ball and unseat the ball of the check valve. In this manner, flow can occur through the checked position. The M673F has a p.o. check valve, located between solenoid "D" and angling port C1 (see any diagram, figure 1-4). When C1 is extended, fluid will flow from the pump through this check valve port C1. The return flow from C2 does not involve the operation of the p.o. check valve. When C2 is extended, the return flow from C1 must pass through the p.o. check. As pressurized fluid is fed to C2, a pilot pressure line to the top of the piston of the p.o. check opens the check valve and allows return flow from C1 back to the reservoir.

Crossover Relief Valves

The modular valve body of the M673F has built into it, two crossover relief valves which, when activated, bleed fluid from C1 to C2 or vice versa (see any diagram, figure 1-4). The crossover relief valves are similar in construction to a regular direct acting relief valve. They are there to help protect the valving in the power pack as well as allowing for the absorption of all but the most severe impact forces that may occur during the plowing operation. In this manner the angling cylinders, the plow frame and the truck frame are protected from the normal impact forces associated with plowing. The crossover relief valves are adjustable and are normally set at about 3000 psi.

Control Switches

The M673F uses three different control boxes: control box with rocker switches, touchpad control box and joystick control box. Each control box performs same functions: up, down, angle left and angle right.

The rocker switches are both 3 position with only the down position on the up/down switch not being spring returned.

When the plow is raised (see diagram, figure 7), the switch permits current to the C-valve as well as the motor solenoid. When the plow is lowered (see diagram, figure 8) or in the float position, only the B-valve sees current. For angling to the right (see diagram, figure 5), C1 is extended. The angling switch then permits current to flow to valve "A" and the motor start solenoid. For angling left (see diagram, figure 6) requiring the extension of C2, current flows through the D-valve and the motor start solenoid.

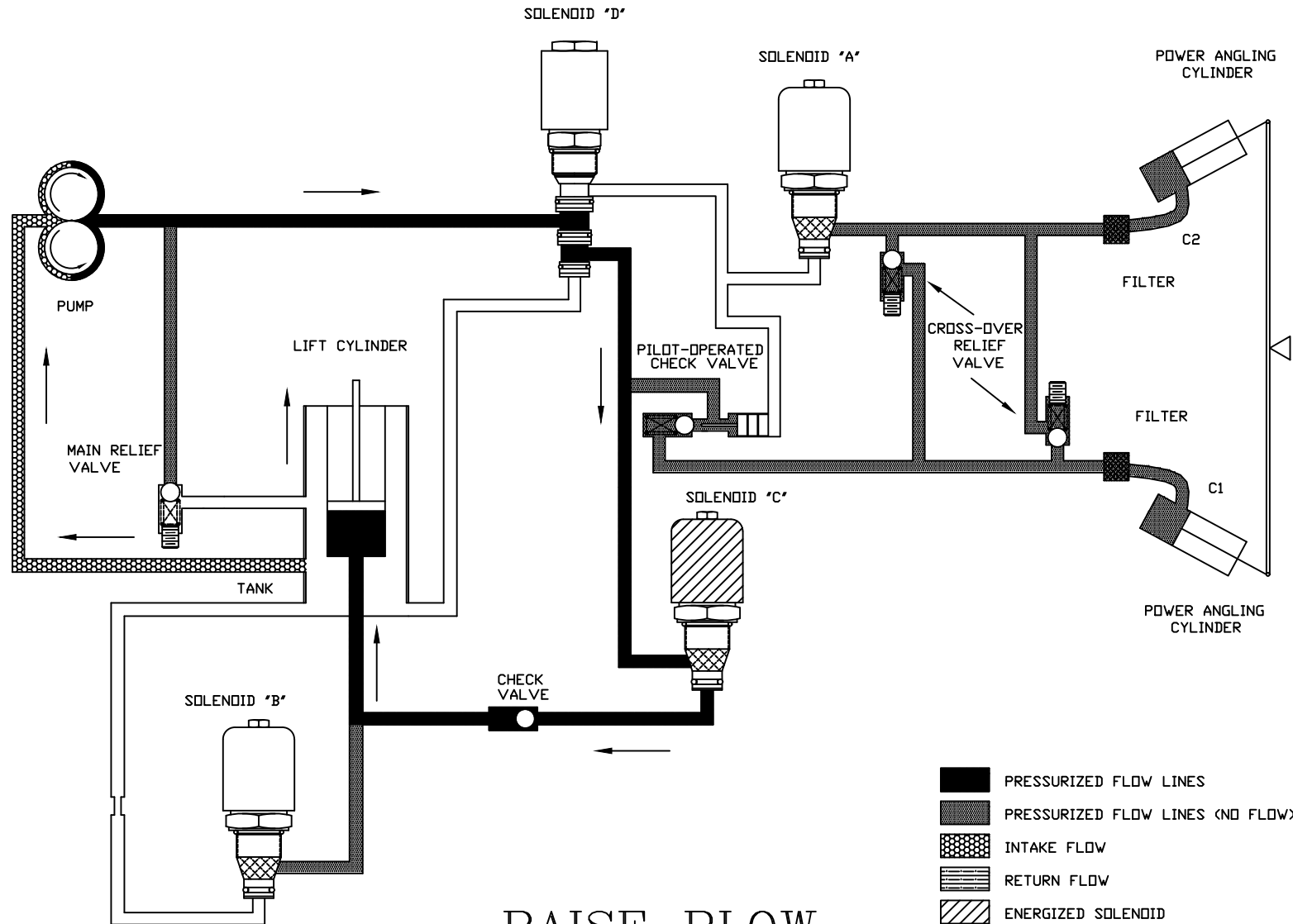

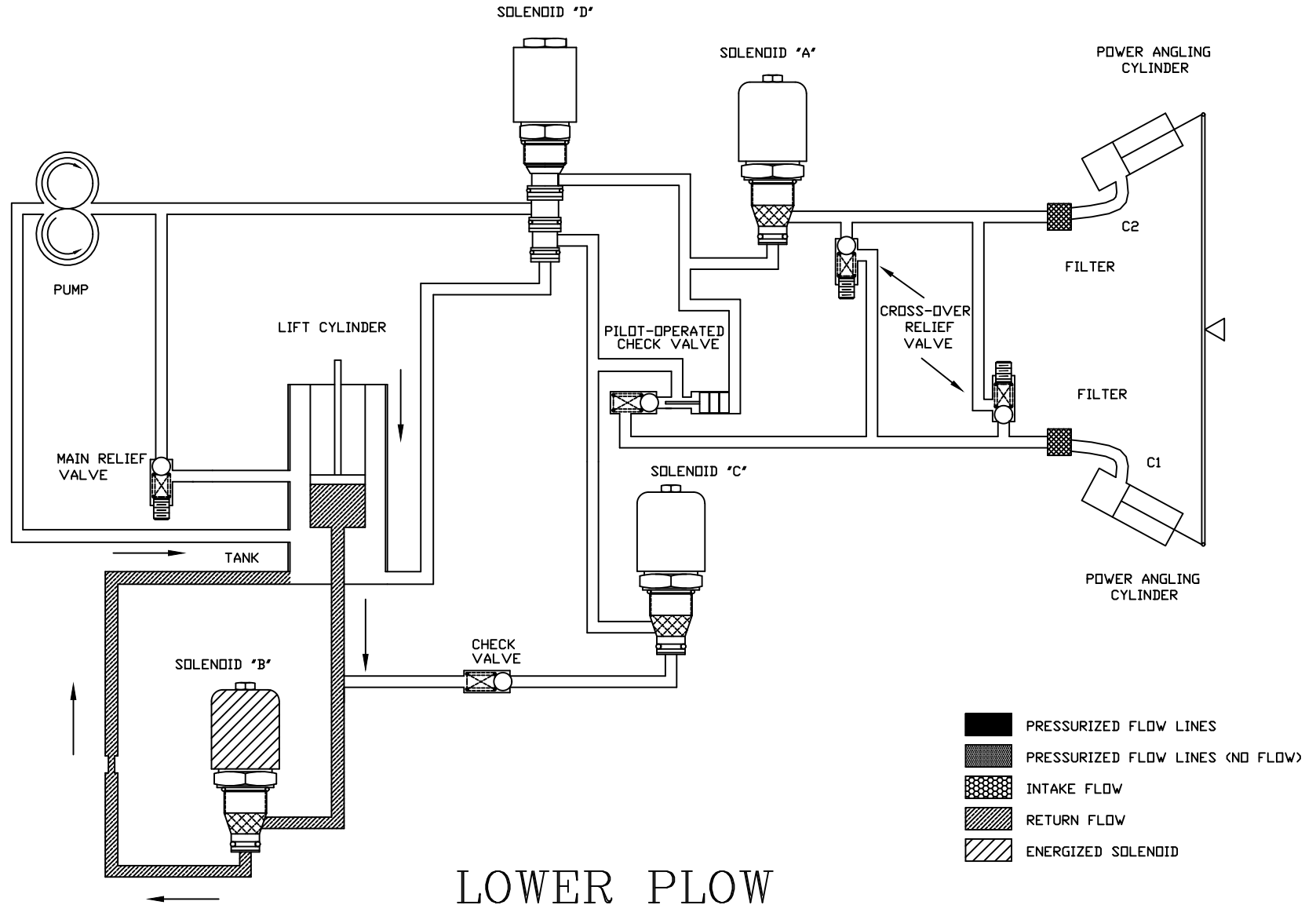

REV 01

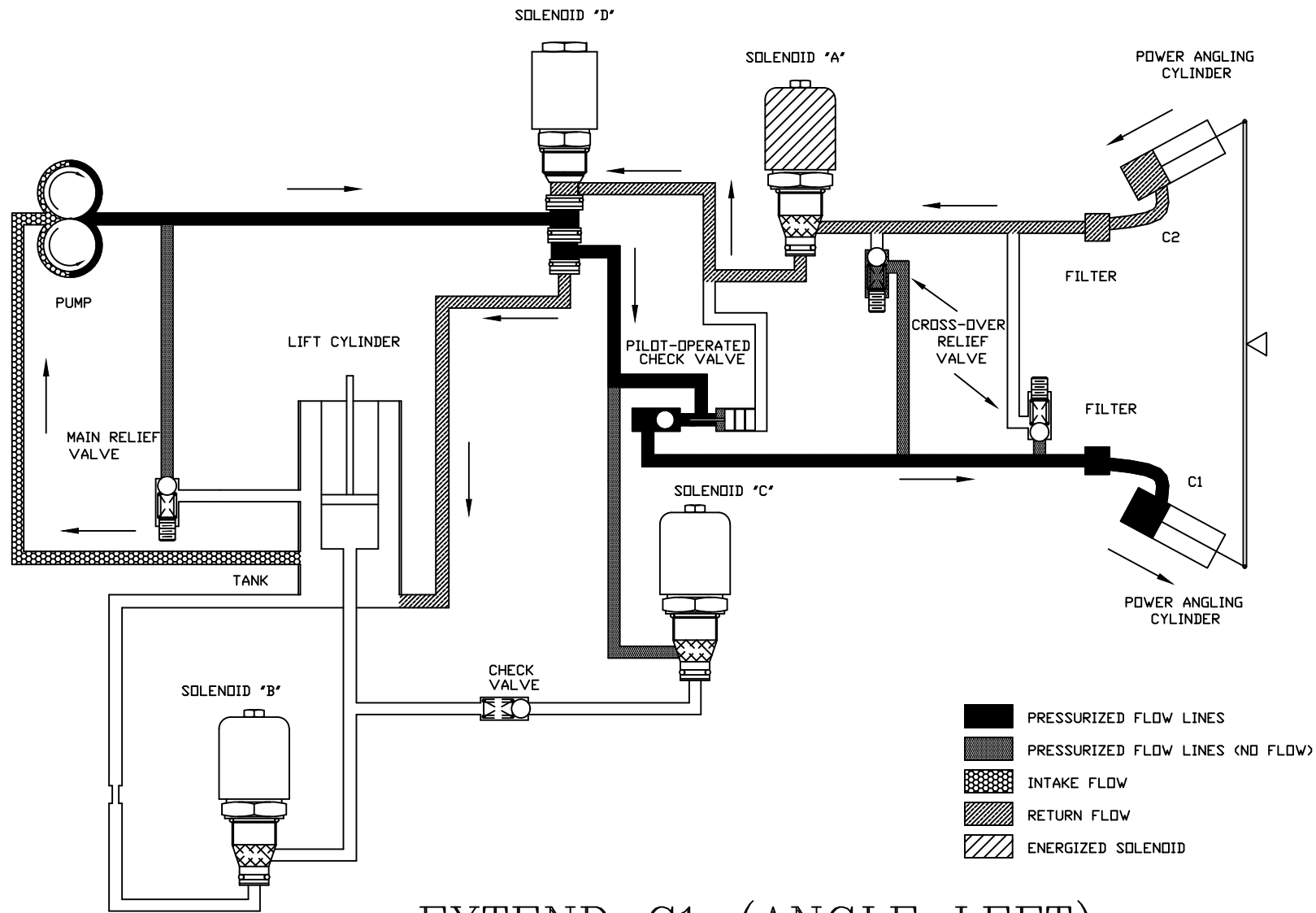

EXTEND C1 (ANGLE LEFT)

FIGURE 1

REV 01

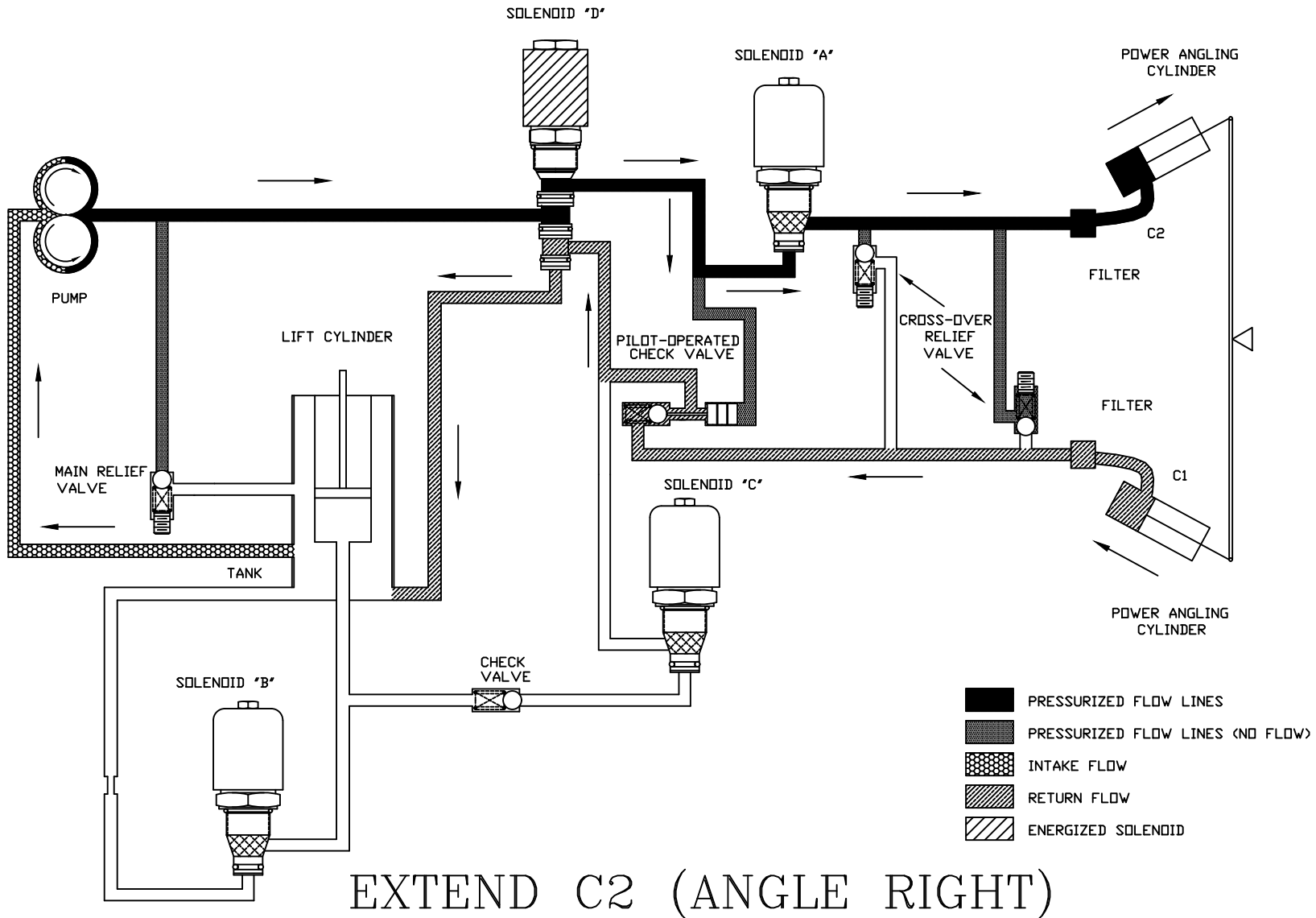
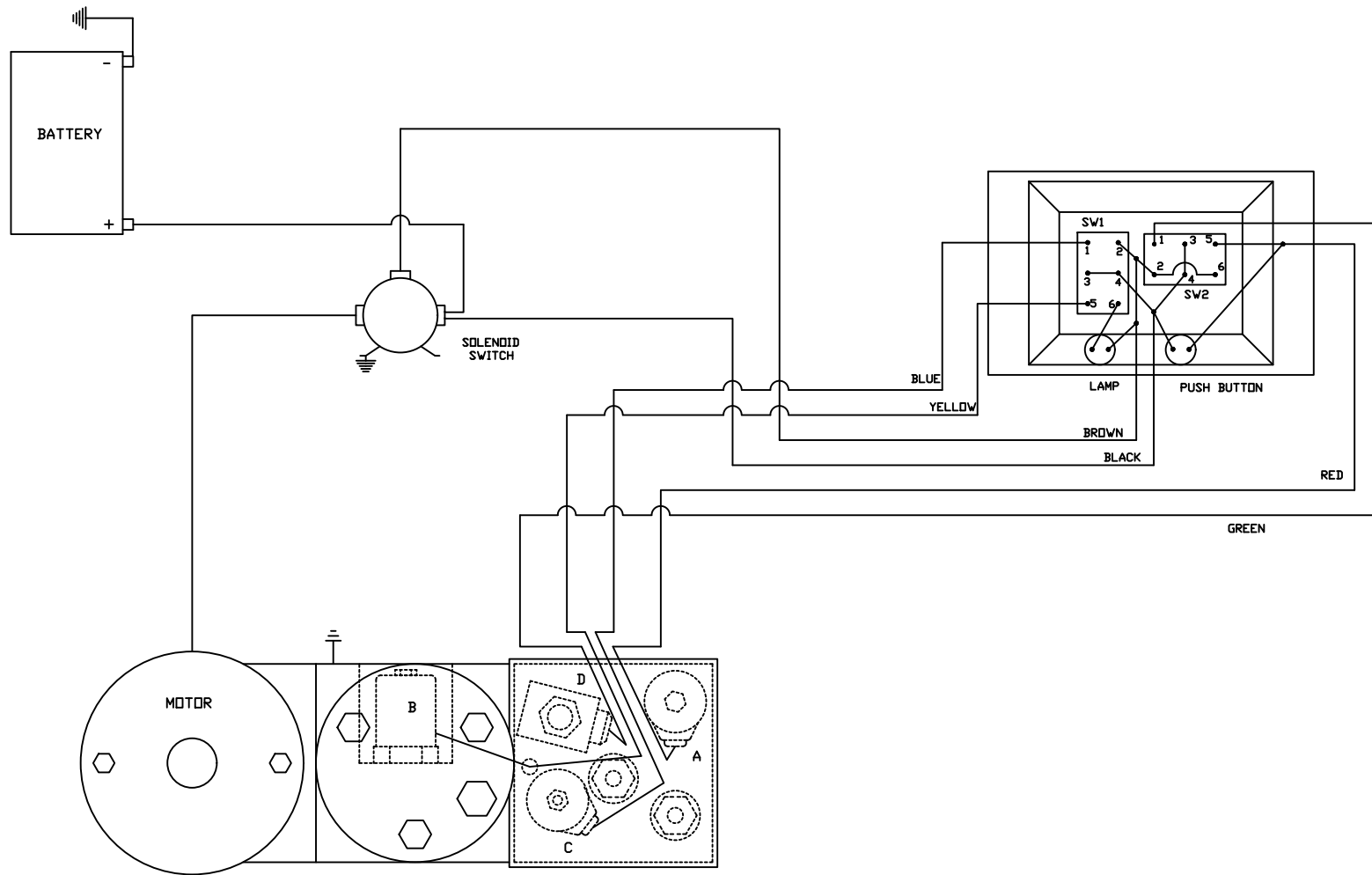

FIGURE 2



RAISE PLOW

FIGURE 7

NOTE: 1. ALL SOLENOID VALVES ARE GROUNDED
 2. THIS DRAWING IS FOR EDUCATIONAL PURPOSES ONLY. REFER TO THE PROPER WIRING DIAGRAM FOR ACTUAL WIRING.

- SOLENOID "C" ENERGIZED
- MOTOR ENERGIZED
- SW1 CONTACTS CLOSED BETWEEN 1&3 AND 2&4

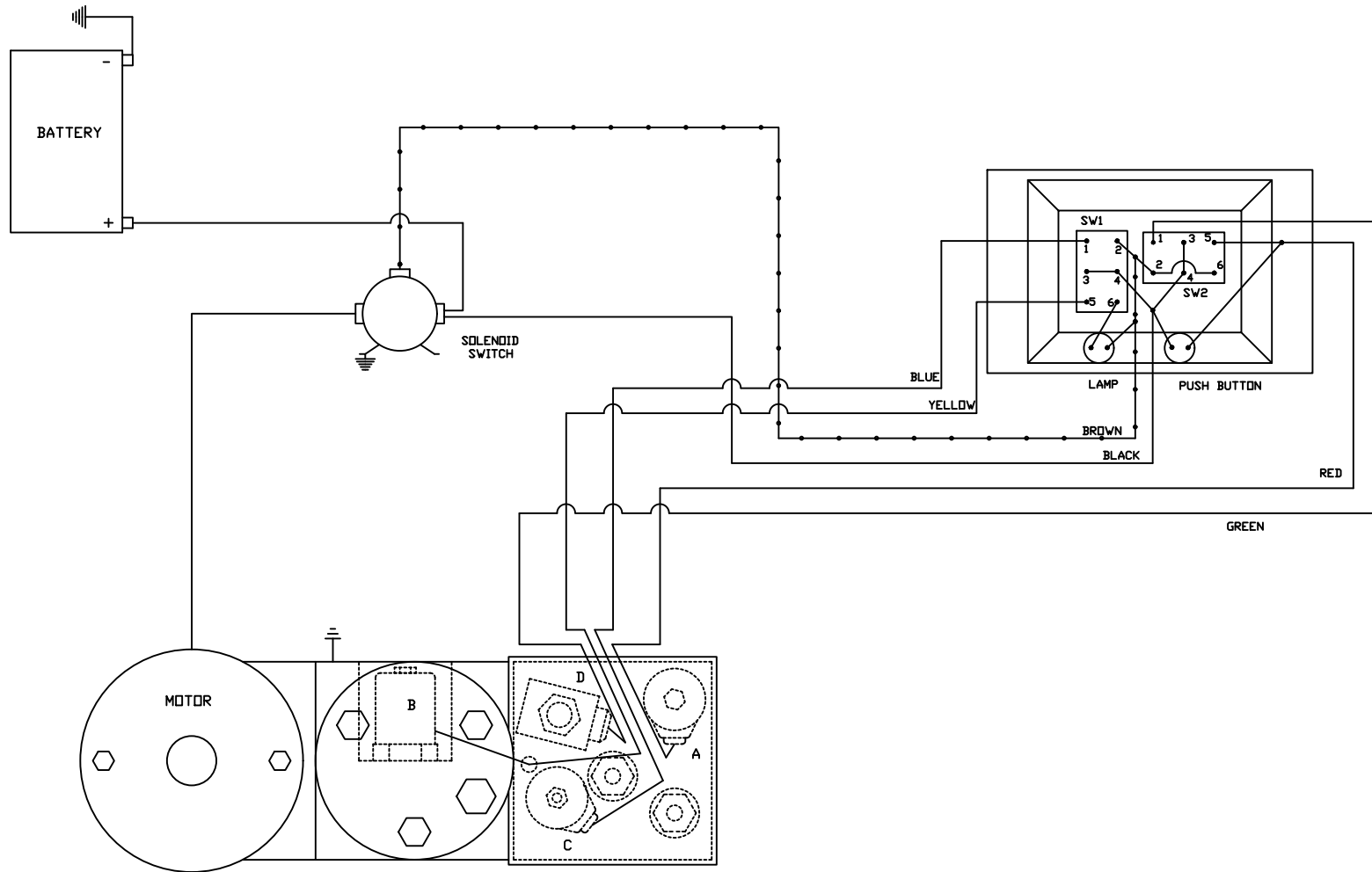

LOWER & FLOAT PLOW

FIGURE 8

- NOTE: 1. ALL SOLENOID VALVES ARE GROUNDED
 2. —•—•— LOW AMPERAGE FOR PISTON ONLY
 3. THIS DRAWING IS FOR EDUCATIONAL PURPOSES ONLY. REFER TO THE PROPER WIRING DIAGRAM FOR ACTUAL WIRING.

- _ SOLENOID "B" ENERGIZED
- _ SW1 CONTACTS CLOSED BETWEEN 5&3 AND 6&4

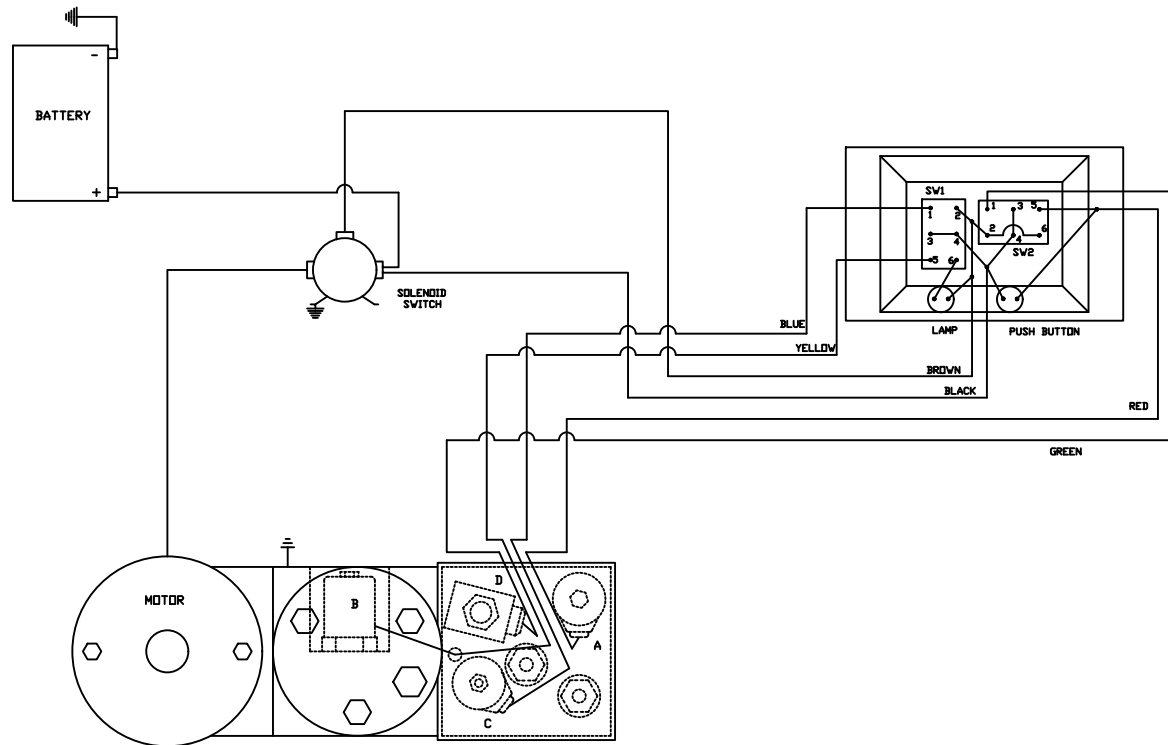

EXTEND C1 (ANGLE LEFT)

FIGURE 5

NOTE : 1. ALL SOLENIOD VALVES
ARE GROUNDED
2. THIS DRAWING IS FOR EDUCATIONAL PURPOSES ONLY.
REFER TO THE PROPER WIRING DIAGRAM FOR ACTUAL WIRING.

- SOLENIOD "A" ENERGIZED
- MOTOR ENERGIZED
- SW2 CONTACTS CLOSED BETWEEN 3&5 AND 4&6

REV 01

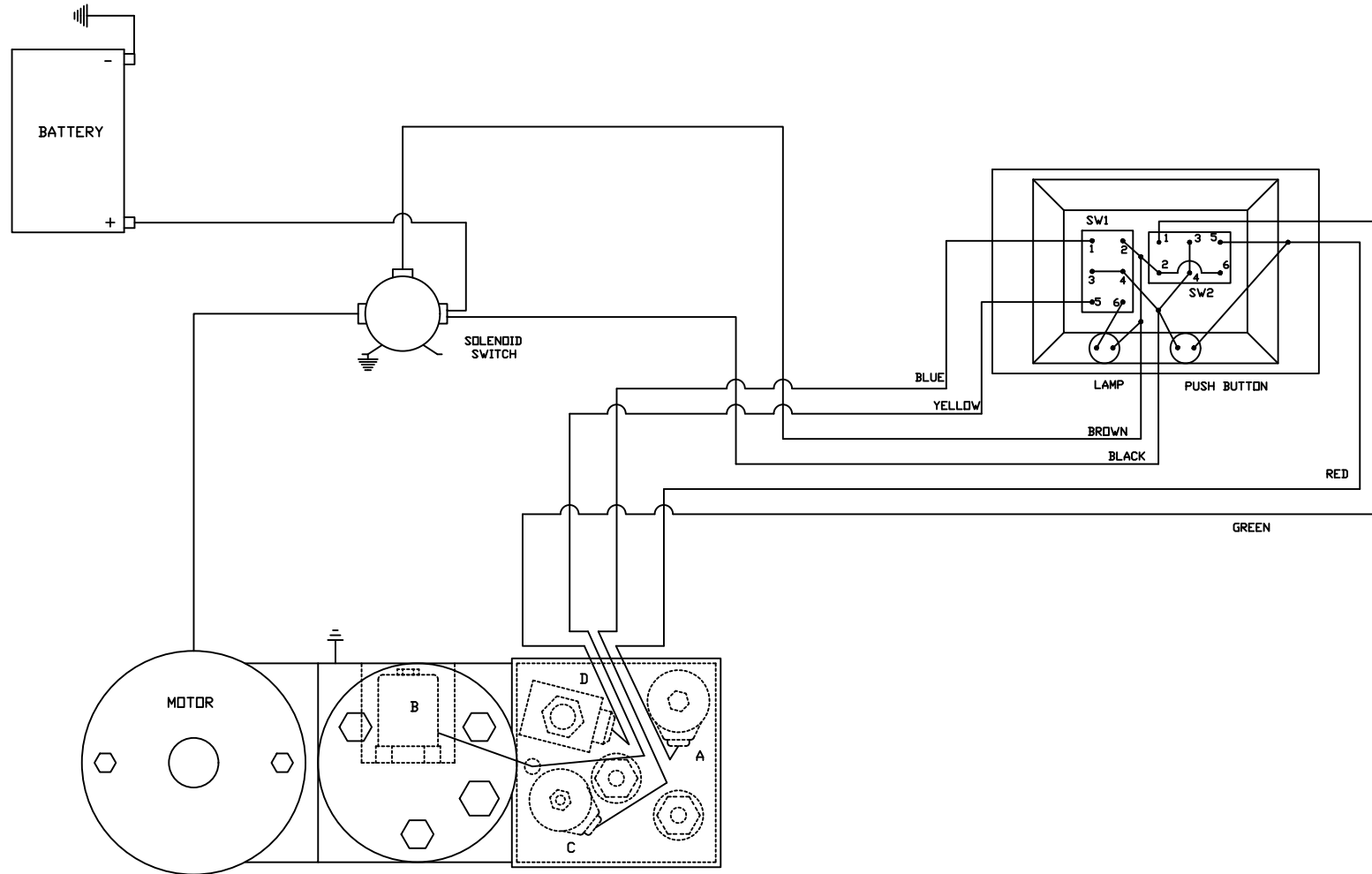

EXTEND C2 (ANGLE RIGHT)

FIGURE 6

NOTE : 1. ALL SOLENOID VALVES
ARE GROUNDED
2. THIS DRAWING IS FOR EDUCATIONAL PURPOSES ONLY.
REFER TO THE PROPER WIRING DIAGRAM FOR ACTUAL WIRING.

- SOLENOID "D" ENERGIZED
- MOTOR ENERGIZED
- SW2 CONTACTS CLOSED BETWEEN 1&3 AND 2&4

REV 01

HYDRAULIC SCHEMATIC FOR M673010-01L06E

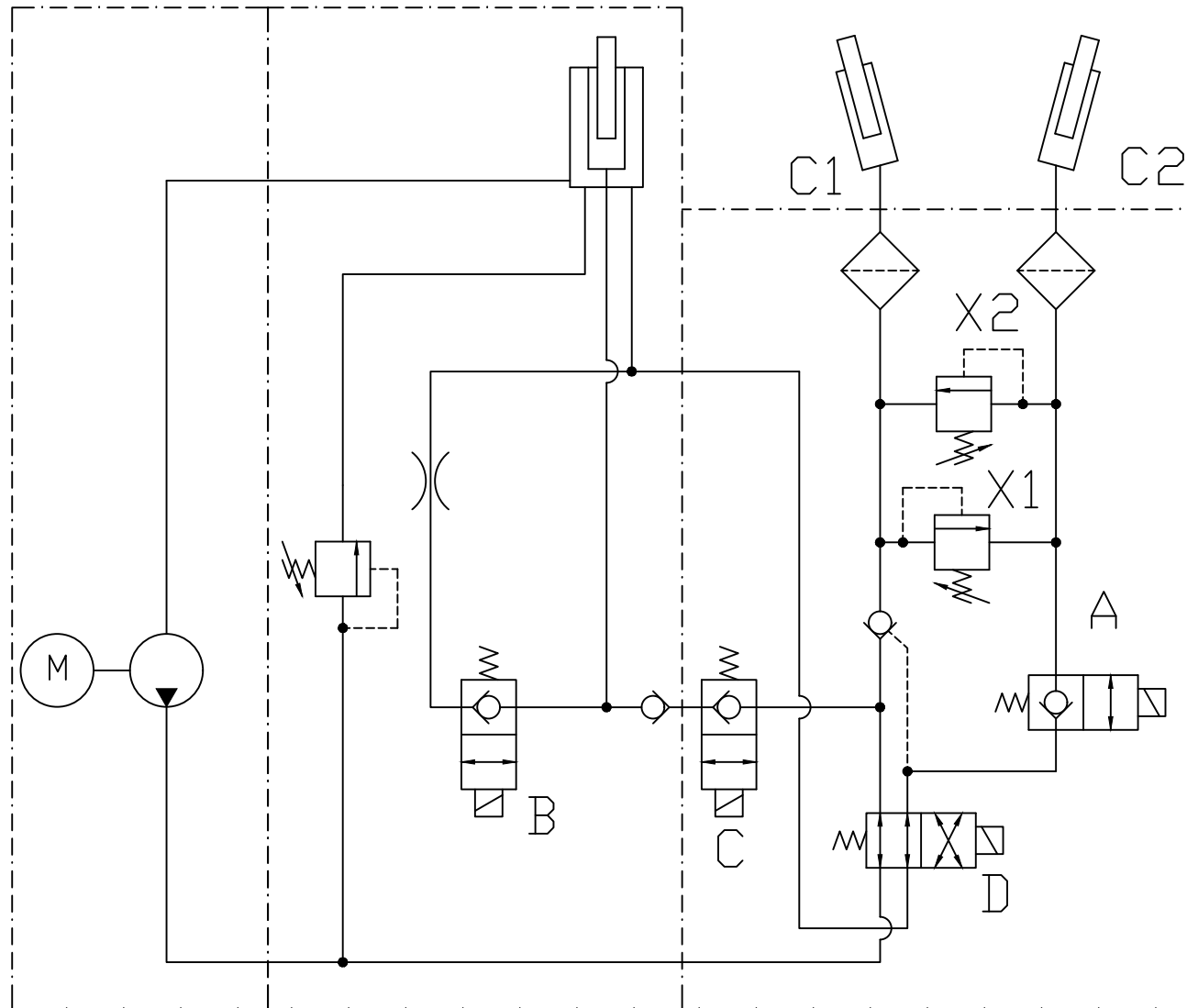

M673F installation instructions

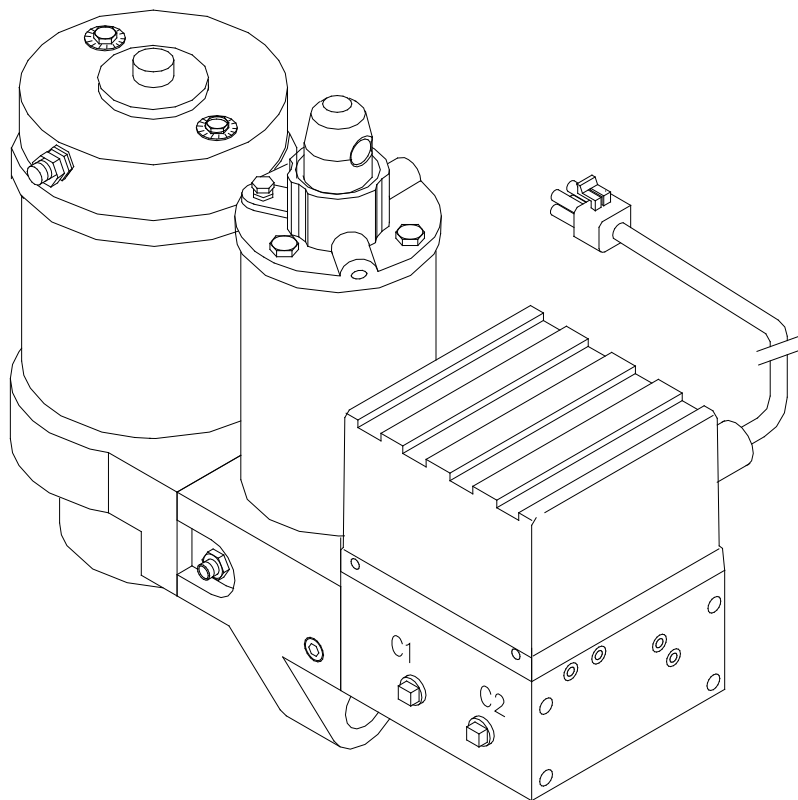

M673F installation instructions

Warning:

- Top of battery needs to be protected. If positive side of battery is accidentally grounded person could be burnt or wiring system can be damaged, or battery gasses could explode causing injuries.
- Disconnect cable from negative battery terminal before start installation.
- Always wear eye protection and protective clothing when working around hydraulic systems.
- Remove jewelry and objects that might conduct electricity while working on power units.
- Fluid under pressure can pierce the skin and enter the bloodstream causing death or serious injury.
- Hydraulic hoses and electrical cables (harnesses) must be tied and routed safely to avoid any damage and pinching (away from hot places, sharp objects etc.).

- Do not use Teflon tape on hydraulic fittings as it can easily jam valves and plug the filters in the system.
 - All electrical connections must be greased with die electrical grease to prevent corrosion.
1. Install power unit (1) to lift frame with motor toward curb side of truck.
 2. Install colour co-ordinated weather covers on cable and plug assembly (2). Attach red lead to positive motor stud and black lead to the ground motor stud. Liberally coat connections with di-electric grease then slide covers (12) (15) over the eyes on the end of the cables.
 3. Mount solenoid (3) to metal surface in engine compartment bending bracket if necessary. Be sure to locate the solenoid so that there is sufficient cable to reach to both the battery cable (5) and the cable and plug assembly (2) on the power unit.
NOTE: Solenoid must be well grounded in order to function properly.
 4. Slide weather cover (9) over power (5) and ground (6) cables and route through grille of truck leaving sufficient length to attach to the cable and plug assembly (2). Secure the red power cable (5) to the large terminal on the solenoid and the black ground cable (6) to the negative terminal on the battery.
 5. Secure power cable (7) from other large terminal on solenoid to positive terminal on

battery.

6. Plug intermediate harness (8) into power unit harness and follow battery cable routing toward firewall. Locate a pass through hole in the firewall near the driver's side of the truck. Route other end of intermediate harness (8) through the hole in firewall and attach control station. **NOTE:** A smaller hole in the firewall can be used if the cable is fed into the engine compartment from the cab as the plug at the power unit end is smaller than at the control station end.
7. Attach white wire to ground, black wire to positive side of solenoid and brown wire to small terminal on top of the solenoid.
8. Neatly secure all excess cables and wires using tie straps. Silicone hole in firewall.

Note: Be sure all cables are properly protected from any sharp edges or hot or moving parts.

9. Install swivel end of 29" hose into port C1. Install 90 degree swivel elbow (10) in curbside (CS) angle cylinder @ 1:00. Connect straight end of 29" hose loosely to swivel elbow.
10. Install 90 degree swivel elbow (10) into driver's side (DS) angle cylinder @ 10:00. Connect straight end of 18" hose loosely to 90 degree swivel elbow on cylinder. Connect 90 degree swivel end of 29" hose into port C2.
11. Remove power unit filler plug and fill reservoir with **UNIVIS J13 (HVI 13)** hydraulic oil. Do not use automatic transmission fluid in this system as it may lead to aeration of the oil in very cold weather conditions. Use of fluid other than J13 will void warranty.
12. Manually angle the plow to one side before activating the power unit. This can be easily accomplished as the hose connections are loose at the angling cylinders.
13. Remove the bleeder hole plug (31). Jog the lift switch until no air is seen in the fluid passing through the bleeder hole. Reinstall and tighten the bleeder plug.
14. Jog the angle switch in the direction of the retracted cylinder until no air is seen in the fluid passing through the loose connection. Tighten fittings. Fully extend this cylinder.
15. Jog the angling switch in the direction of the other cylinder until no air is seen in the fluid passing through the loosened connection. Tighten fittings.
16. Refill power unit so that oil level is ¼" from the top of the reservoir. Clean up any spilled oil and check all functions several times making sure there is not excessive foaming in the reservoir. Compress the lift cylinder and double check the oil level. Check for leaks at all fittings and reinstall filler plug. Filler plug only has to be snug. Do not torque closed.

52209-05-M M673F Power Unit Kit for Quik-Link Mounting Style/ 52209-06-M M673F Power Unit Kit for Bush Guard Mounting Style			
Item	Part Number	Description	Quant.
1	M673F-01	M673F010-01L27E power unit	1
2	3004665	Cable and plug assembly	1
*3	FP17757	Solenoid	1
5	1306120	63" Power Cable	1
6	13061221	54" Ground Cable	1
7	1306340	22" Battery Power Cable	1
8	FPN0457-SA	Intermediate Harness	1
**9	0203300	Weather Cover for power and ground cable	1
10	HH-00794-003	90 degree swivel elbow	2
11	51003-N	Quick Disconnect (Includes Male & Female)	2
**12	52427-N	Red Terminal Protector	1
13	51904-M	29" Hose Assembly	1
14	51002-M	18" Hose Assembly	1
**15	52428-N	Black Terminal Protector	1
16	52315-N	Harness dummy plug	1
17	490056-01	½ oz tube die electric grease	1

Note:

* Item 3 was part # FP7518

**Items not shown on drawing.

M673F WIRING INSTALLATION

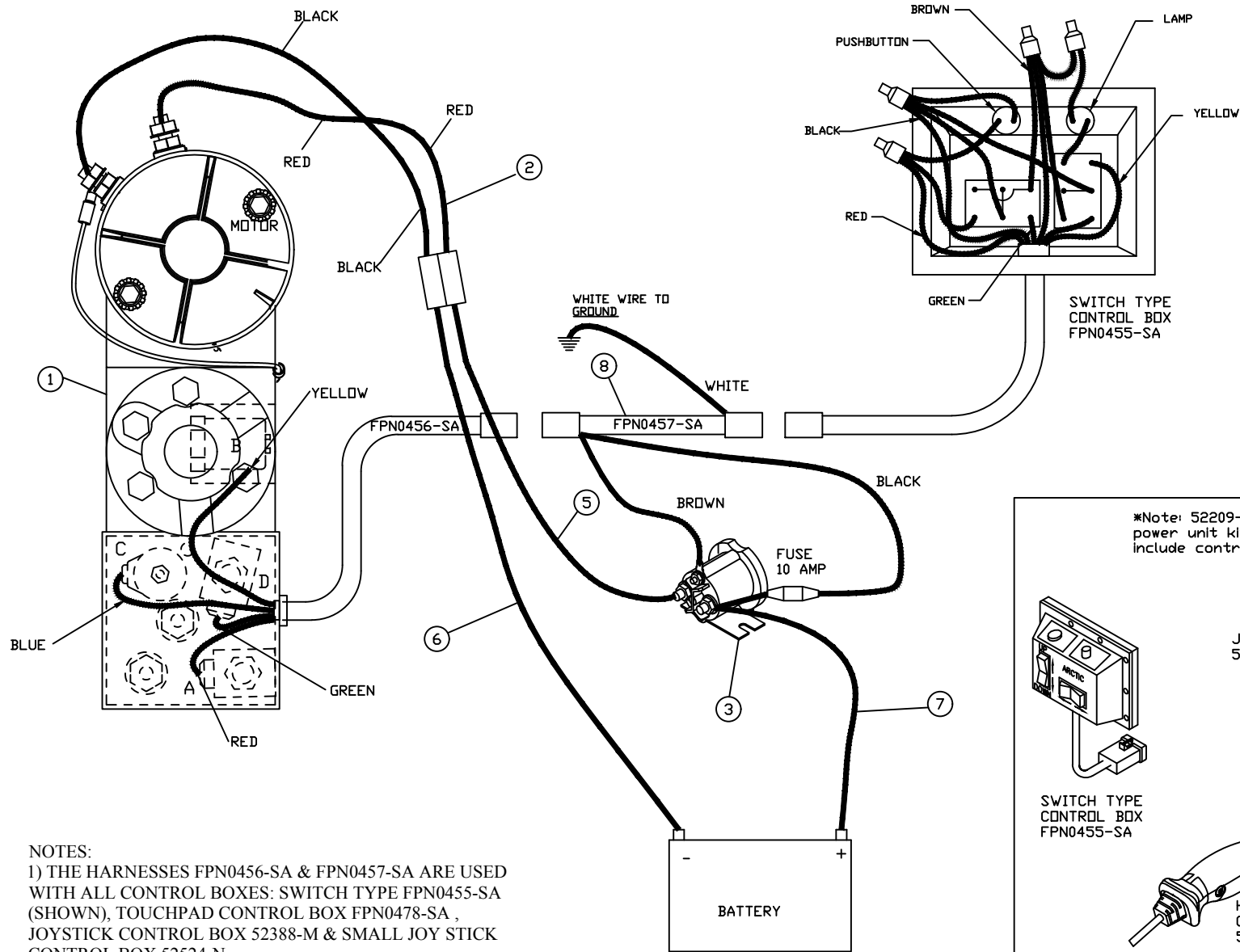

NOTES:
 1) THE HARNESSSES FPN0456-SA & FPN0457-SA ARE USED WITH ALL CONTROL BOXES: SWITCH TYPE FPN0455-SA (SHOWN), TOUCHPAD CONTROL BOX FPN0478-SA, JOYSTICK CONTROL BOX 52388-M & SMALL JOY STICK CONTROL BOX 52524-N.

*Note: 52209-05-M & 52209-06-M power unit kit does not include control box.

SWITCH TYPE CONTROL BOX FPN0455-SA

JOY STICK, 53647-1PC

HANDHELD CONTROLLER 53276-N

M673F HOSE AND FITTING INSTALLATION

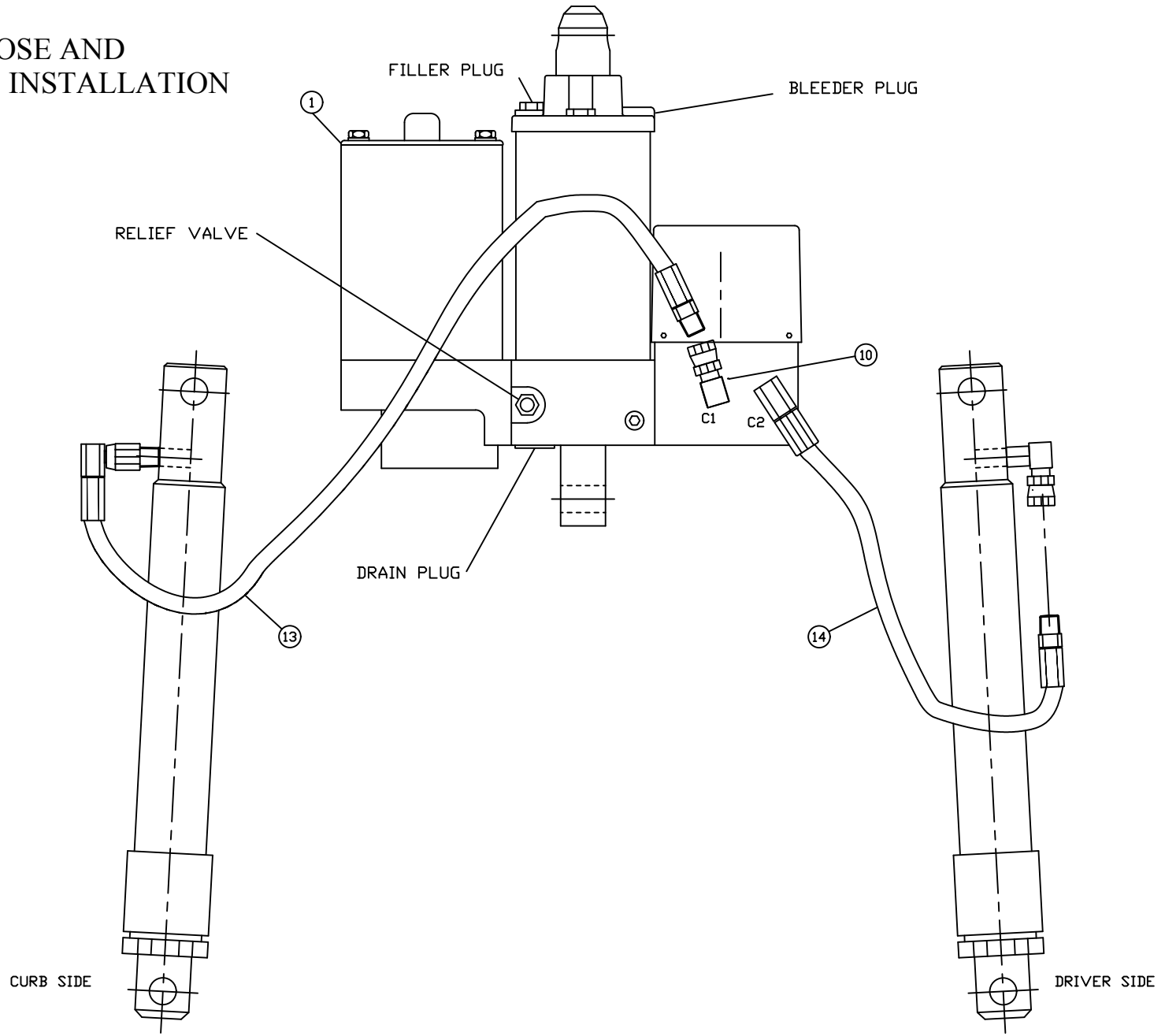

M673F010-01L06E

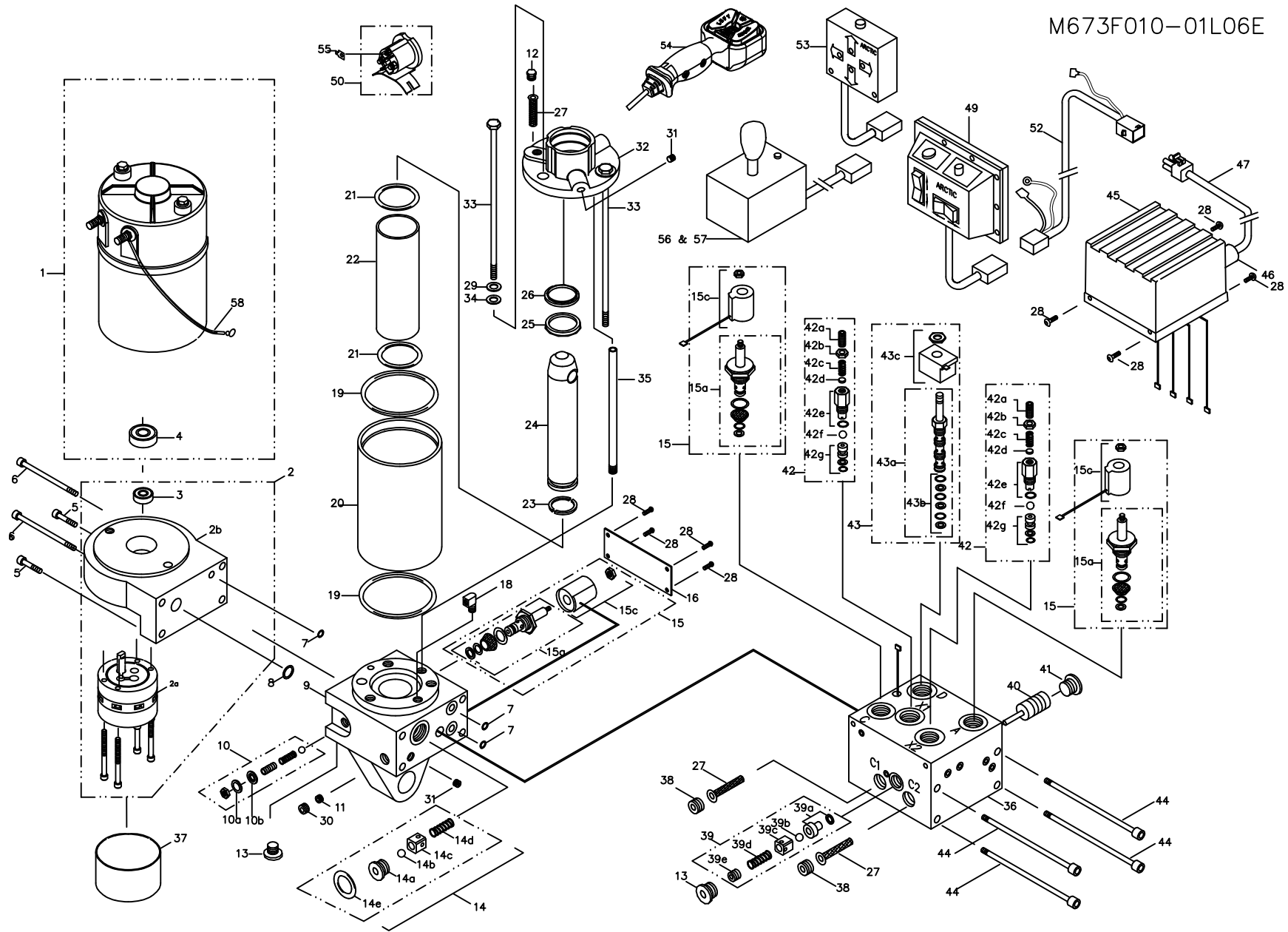

M673F Old- Parts List				
Rev	Ref #	Qty	Part #	Description
R2	1	1	FP18442	Electric Motor, 12V DC
R3	1a	1	FP8714	Brush Kit for ISKRA motor (FP18442)
	1b	1	52589-M	Brush Kit for Prestolite Motor (FP8034)
	2	1	FPN0733-SA	Pump and Base Assembly, 03 Gear
R1	2a	1	FPK-12311-250	Modular Pump Kit,03 Gear
	2b	1	FPN0856-SA	Base Ass'y c/w seal
	2c	1	FP7985	Needle Bearing (Pump Shaft to Pump Base)
	3	1	FP2159	Seal, Pump shaft
	4	1	FP2318	Bearing, Motor to Pump Base
	5	2	FPN0582	Screw, SHCS, 1/4-20UNC * 1.0
	6	2	FPN0364	Screw, SHCS, 1/4-20UNC * 4.5
	7	3	FP0117	'O'-Ring, 1/16 * 3/8 ID * 1/2 OD, 2-012,
	8	1	FPN0055	'O'-Ring, 3/32 * 7/16 ID * 5/8 OD, 2-111,
	9	1	FPN0553-SA	Center Block Ass'y (c/w relief valve, check valve, B valve, o-rings)
	10	1	FP7527	Parts Kit, Relief Valve Assembly (c/w washer part #FPN0575)
	11	1	FP4371	Plug, Orifice, 3/64" Hole (1/16-27 NPTF)
	12	1	FPN0585	Plug, Pipe, Hex, 1/4 -NPT
	13	2	FP3276	Plug, Hollow Hex, SAE O-Ring, 9/16-18UNF
	14	1	FPN0558-SA	Check Valve Kit, 5/16 Ball
	14a	1	FPN0557	Seat, 5/16
	14b	1	FP0126	Ball, 5/16
	14c	1	FP2680	Poppet, Ball Retainer
	14d	1	FP0130	Spring
	14e	1	FPN0037	'O'-Ring, 1/8 * 11/16 ID * 15/16 OD, 2-209,
R3	15	3	FP0490	Valve, #8S, 2 Way, 2 Pos, NC Poppet, 12V DC, Single Wire
R3	15a	3	FP10907-D	Valve, #8S, 2 Way, 2 Pos, NC Poppet, Cartridge Only
R3	15c	3	FP10861-D	Coil, 12VDC
	16	1	FPN0343	Center Block Valve Cover
	18	1	FPN0393	Street Elbow, Extruded Brass, 1/8 NPT
	19	2	FPN0358	'O'-Ring, 3-1/4 ID * 3-7/16 OD * 3/32, -152, 90 Duro
	20	1	FPN0346	Reservoir Tube, 3-3/4 OD x 6-3/8 Lg
	21	2	FPN0306	'O'-Ring, 2 ID * 2-3/16 OD * 3/32, -136, 90 Duro
	22	1	FPN0304	Cylinder Tube, 2" OD x 6-3/8 Lg
	23	1	FP5575	Split Ring, Stop 1 1/2 Rod
	24	1	FPN0305	Cylinder Rod, 1-1/2" OD x 10" Lg
	25	1	FPN0356	Rod Seal, 1.5" PolyPack Type B

M673F Old- Parts List				
Rev	Ref #	Qty	Part #	Description
	26	1	FPN0355	Rod Wiper, U Wiper, 1.5"
	27	3	FP1316	Filter, Finger Screen
	28	8	FPN0546	Screw, Plated, #10-24UNC * 3/8"
	29	3	FP1970	Washer, Plated
	30	1	FP2355	Plug, Pipe, Flush, 1/8 NPT
	31	2	FP7669	Plug, Pipe, Flush, 1/16-27-NPTF
	32	1	FPN0547-SA	Cylinder Head Assembly)c/w wiper, seal and O-rings)
	33	3	FPN0360	Bolt, Hex Head, Grade 8, 3/8-16UNC * 7.5
	34	3	FPN0359	Seal Washer, 3/8
	35	1	FPN0307	Tube, Steel, 5/16 * 6.25 Lg, 1/16 NPTF 1 end
	36	1	FPN0556-SA	Manifold Ass'y (c/w PO check valve and x-over)
	36a	1	52793-M	Manifold Assembly c/w all valves
	*37	1	FPN0719	Plastic Cap
	38	2	FP7624	Screw, Spring Retainer, 9/16-18UNC
	39	1	FP3624	Check Valve Kit
	39a	1	FP2420	Seat, Poppet
	39b	1	FP0126	Ball, 5/16
	39c	1	FP2680	Poppet, Ball Retainer, Check
	39d	1	FP0130	Spring, Light, Check Valve
	39e	1	FP7732	Screw, spring retainer
	40	1	FP0061	Piston, Assembly, Pilot Check
	41	1	FP3274	Plug, SAE #8
	42	2	FP13023	Relief Valve, cross over
	42a	2	FP7899	Screw, S Set, Oval P, 3/8-16UNC * 1.25
	42b	2	FP0386	Nut, Sealing, 3/8-16UNC
	42c	2	FP0147	Spring
	42d	2	FP1288	Shim, Spacer
	42e	2	FP0379	Housing, Adj. Rel. Valve Ball Type
	42f	2	FP0012	Ball, 1/4"
	42g	2	FP0378	Seat, X-Over Rel, Ball Type
R3	43	1	FP10833-D	Valve, #8, 4 Way, 2 Pos, Spool, 12V DC, Single Lead
R3	43a	1	FP11111	Valve, #8, 4 way, 2 Pos, Spool, Cartridge only
	43b	1	FPN0407	Seal Kit, Cartridge Valve
R3	43c	1	FP18835-D	Coil, 10 VDC
	44	4	FPN0365	Screw, SHCS, 1/4-20UNC * 4.25
	45	1	FPN0339	Manifold Valve Cover, Front Mount Plow Unit
	46	1	FP1414	Fitting, Plastic Strain Relief, 1/2" cord
	47	1	FPN0456-SA	Harness, Valve Section End

M673F Old- Parts List				
Rev	Ref #	Qty	Part #	Description
	48	4	FPN0002	Connector, Panduit
	49	1	FPN0455-Sa	Control Station, Rocker Switch
R4	50	1	FP17757	Solenoid, 12 VDC, 3 Pole, Grounded Coil
	52	1	FPN0457-SA	Harness, Center Section
	53	1	FPN0478-SA	Control Box Assembly, Touchpad
	54	1	53282-M	New Handheld controller
	55	1	FP3414	Terminal, #10 Stud Tab
	56	1	52388-M	Joystick, Control Box Assembly
	57	1	53186-M	Small Joystick Assembly
	58	1	53330-A	Motor to Base Ground Wire

- R1: Cap FPN0719 is included with pump modular kit FPK12311-250 & it is not included with pump base assembly FPN0733-SA

- R2: FP18442 replaces FP8034

R3:

- FP0490-D was FP0490
- FP10907-D was FP0307 *note: if Deltrol cartridge with 3/8 stem FP0307 is replaced with Deltrol cartridge with 1/2 stem FP10907-D, coil must also be replaced with FP10861-D
- FP10861-D was FP0496 *note: If coil FP0496 is replaced with FP10861-D, Deltrol cartridge with 3/8" stem must also be replaced with Deltrol 1/2 stem FP10907-D
- FP7249-D was FP7249
- FP0679-D was FP0679 *note: If Parker cartridge FP0679 is replaced with Deltrol cartridge FP0679-D, Parker coil must also be replaced w/ Deltrol coil FP18835-D
- FP18835-D replaces FP10977
- FP11111 replaces FPN0406 *note: if Parker cartridge FPN0406 is replaced with Deltrol Cartridge FP11111, Parker coil FPN0408 must also be replaced with Deltrol coil FP18835-D
- FP10833-D replaces FPN0352
- R4: Fp17757 replaces FP7518

Valves 2 way /2 position (2w/2p) cavity (O-ring) change

1. Power units manufactured prior to 2010

Typically manufactured with "Monarch-style" valve cavity, identifiable by:

- a) Cavity without identification mark (without Greek letter delta (triangle))
(see picture 1)
- b) Black O-ring, with 0.070" cross-section (see picture 3)



2. Units manufactured in 2010 and beyond

Typically manufactured with "Industry standard" valve cavity, identifiable by:

- a) Cavity with identification mark - Greek letter delta (triangle) (see picture 2)
- b) Blue O-ring, with 0.087" cross-section (see picture 3)

Valve replacement

- a) Cavity and O-ring **must be selected correctly** for proper sealing function, the rest of the valve is the same. If necessary, replace O-ring with the proper O-ring to match the valve cavity:
- b) Cavity without identification mark requires black O-ring, with 0.070" cross-section (see picture 3)
- c) Cavity with identification mark require blue O-ring, with 0.087" cross-section (see picture 3)

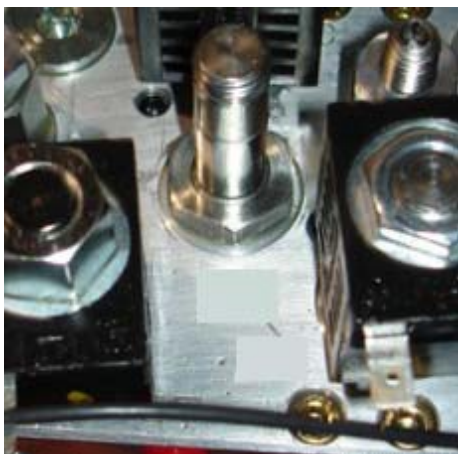

Picture 1



Picture 2

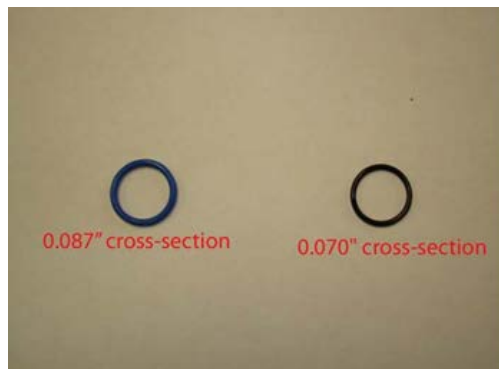

Picture 3

Troubleshooting flow chart for power unit M673F (old version)

- Motor does not operate.
- Snow plow does not raise.
- Snow plow raises up very slow.
- Snow plow will not lower.
- Snow plow leaks down.
- Snow plow angles before raising up.
- Snow plow does not angle to left.
- Snow plow does not angle to right.
- Snow plow does not hold angle.

Warning:

- Top of battery needs to be protected. If positive side of battery is accidentally grounded person could be burnt or wiring system can be damaged, or battery gasses could explode causing injuries.
- Disconnect cable from negative battery terminal before replacing the motor or solenoid.
- Always wear eye protection and protective clothing when working around hydraulic systems.
- Remove jewelry and objects that might conduct electricity while working on power units.
- Fluid under pressure can pierce the skin and enter the bloodstream causing death or serious injury.
- When adjusting the relief valve be sure to use a pressure gauge. Failure to accurately set the relief valve can cause failure resulting in damage to the equipment or cause bodily harm

Specification:

- Max Amp Draw 230 AMP (AMP draw of motor should be measured at maximum raise or maximum angle when motor is running at pressure setting at 2250 psi).
- Note: Do not operate motor continuously for more than 30 sec.
- Relief valve setting 2250 psi.
- X-over relief valve setting 3000 psi.
- Note: Quick couplers are an optional item. If unit is not equipped with quick couplers, disregard troubleshooting steps involving them.

Troubleshooting tips for M673F:

1. Pump shaft can be turned freely (smoothly) using two fingers. If it can't be turned replace pump. Proper pump rotation is clockwise looking from the motor end.
2. Use a screwdriver to check magnetism of solenoid coils. Place screwdriver on the nut securing the coil and have the switch operated. Strong magnetic attraction should be felt.
3. Measure pump pressure at an angle hose (at full angle) it has to be 2250 psi (assuming that cross over relief valve setting is 3000 psi, if cross over relief valve setting is less than relief valve setting pressure gage will read lowest reading). The most accurate reading of system pressure is reading pressure on lift cylinder. When testing or making adjustments on the relief valve the system must be "dead headed" (cylinder at full stroke or in a position where cylinder movement is zero).
4. AMP draw of motor should be measured at maximum raise or maximum angle when motor is running at 2250 psi.
5. Use volt meter or test light to test for power in a harness or continuity in a switch. A test light is simply a light bulb which has one end connected by a wire to an alligator clip and the other end connected to a metal probe. It is used to check the electrical circuit when the battery is connected to the system. The alligator clip is grounded and the light glows when the probe comes in contact with a "live" electrical component.
6. Do not screw cartridge valves into cavity too fast; use a back and forth motion and have O-rings well lubricated.
7. Clean all parts thoroughly before assembly and lubricate with clean oil.
8. Do not use Teflon tape on hydraulic connections as it can easily jam the valves and plug the filters in the system, use pipe sealant. Never apply pipe sealant at the end of fitting, always 2 - 3 threads back.
9. X-over pressure could be set using hand (hydraulic) pump. Example: If you want to set the pressure at x-over X1 insert hand pump hose in the C1 port together with pressure gage. Loosen the jam nut and turn adjusting screw clockwise a turn or two and watch the gauge; if it goes up, continue to turn the screw until the required setting is reached. Retighten the jam nut. To set X-over X2 repeat the same steps as setting X1.
- 10 .To adjust relief valve:
 - a. Loosen jam nut counter-clockwise.
 - b. Turn screw clockwise to increase pressure or turn screw counter-clockwise to decrease pressure.
 - c. Tighten jam nut clockwise to 50in.lb. torque.
 - d. Check system pressure after jam nut is tight. Readjust pressure if screw is moved during tightening of jam nut.

MOTOR DOES NOT OPERATE M673F(old version)

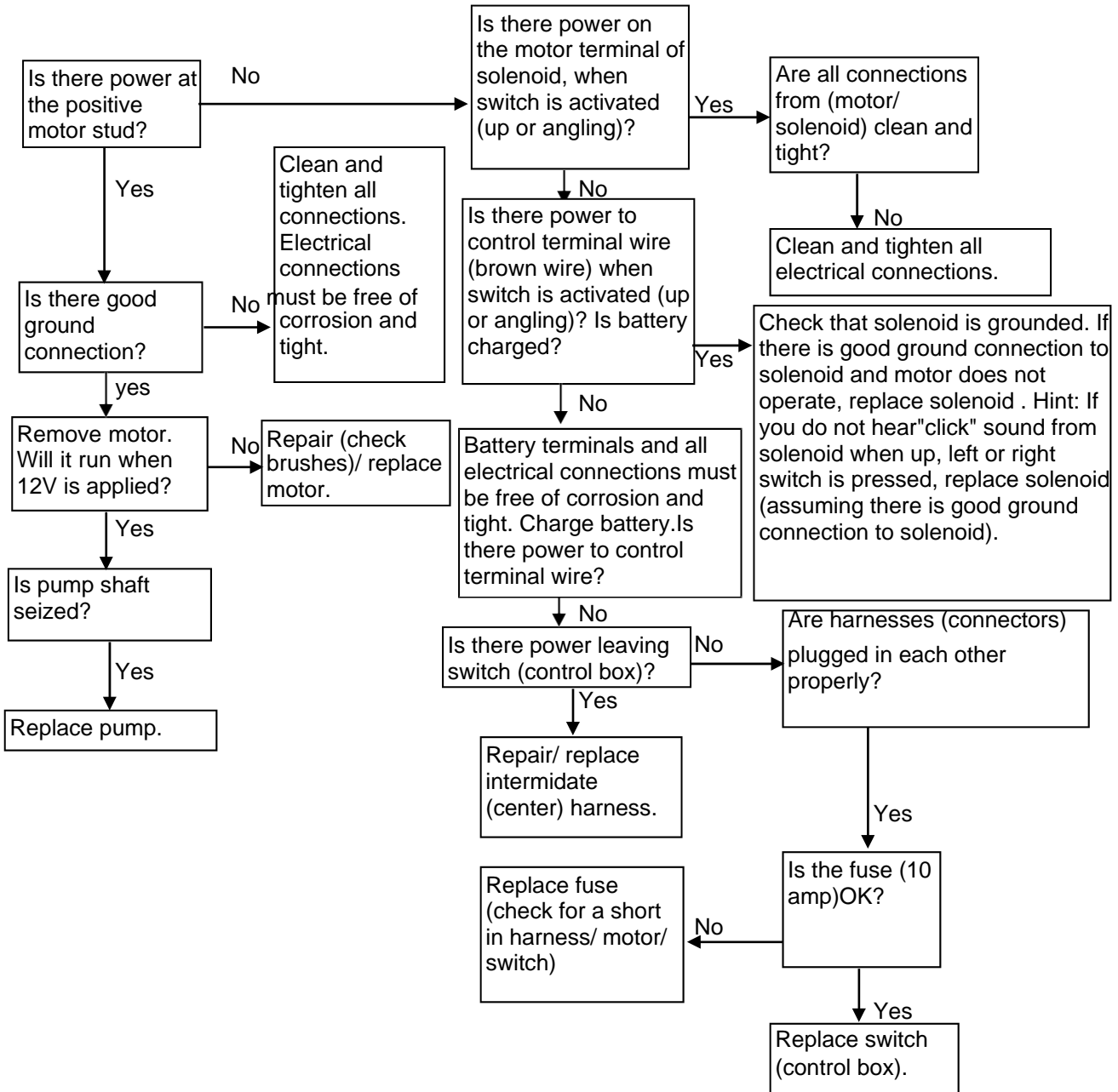

MOTOR OPERATES CONTINUOUSLY M673F (old version)

If motor operates continuously, change solenoid.

SNOW PLOW DOES NOT RAISE M673F(old version)

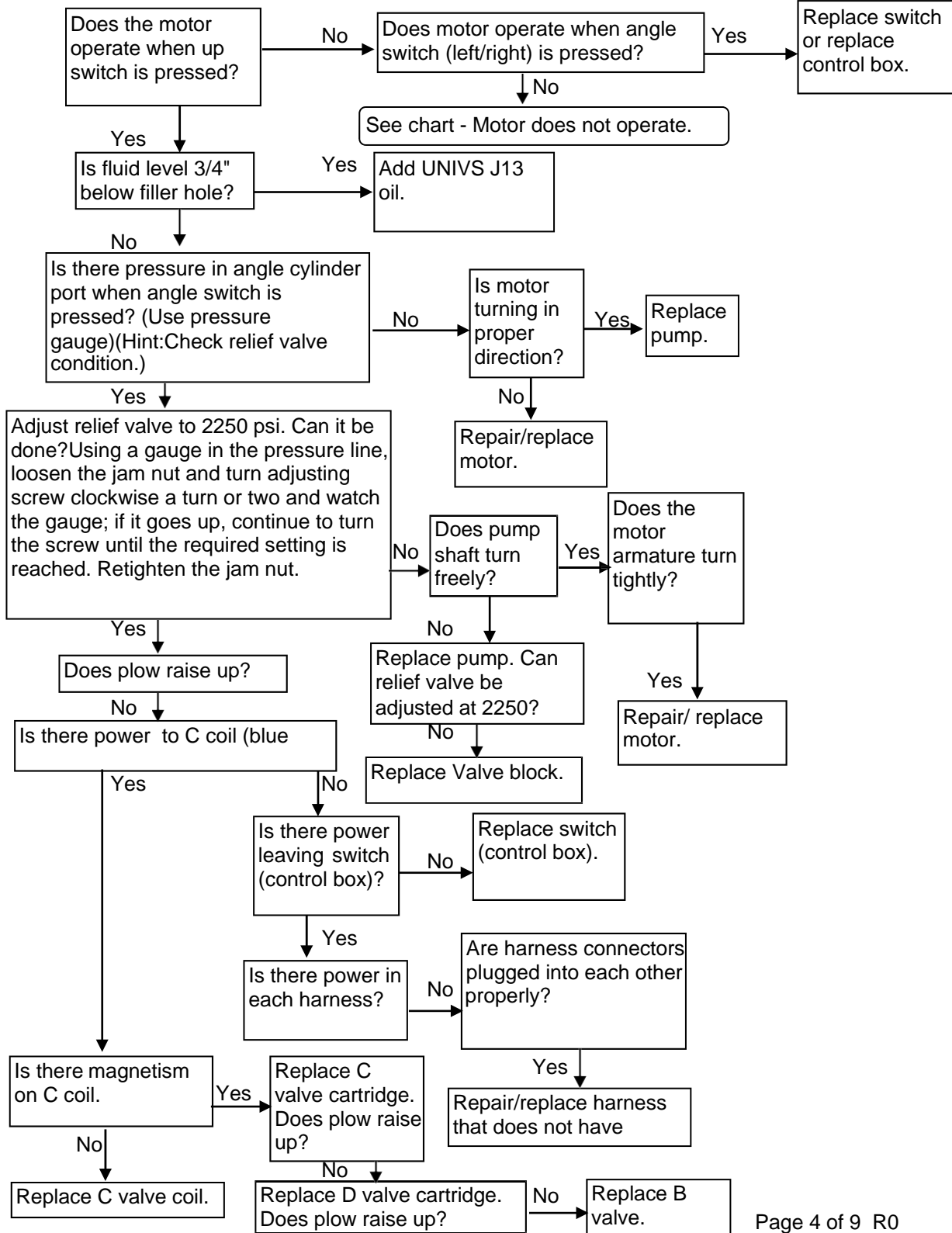

SNOW PLOW RAISE VERY SLOW M673F(old version)

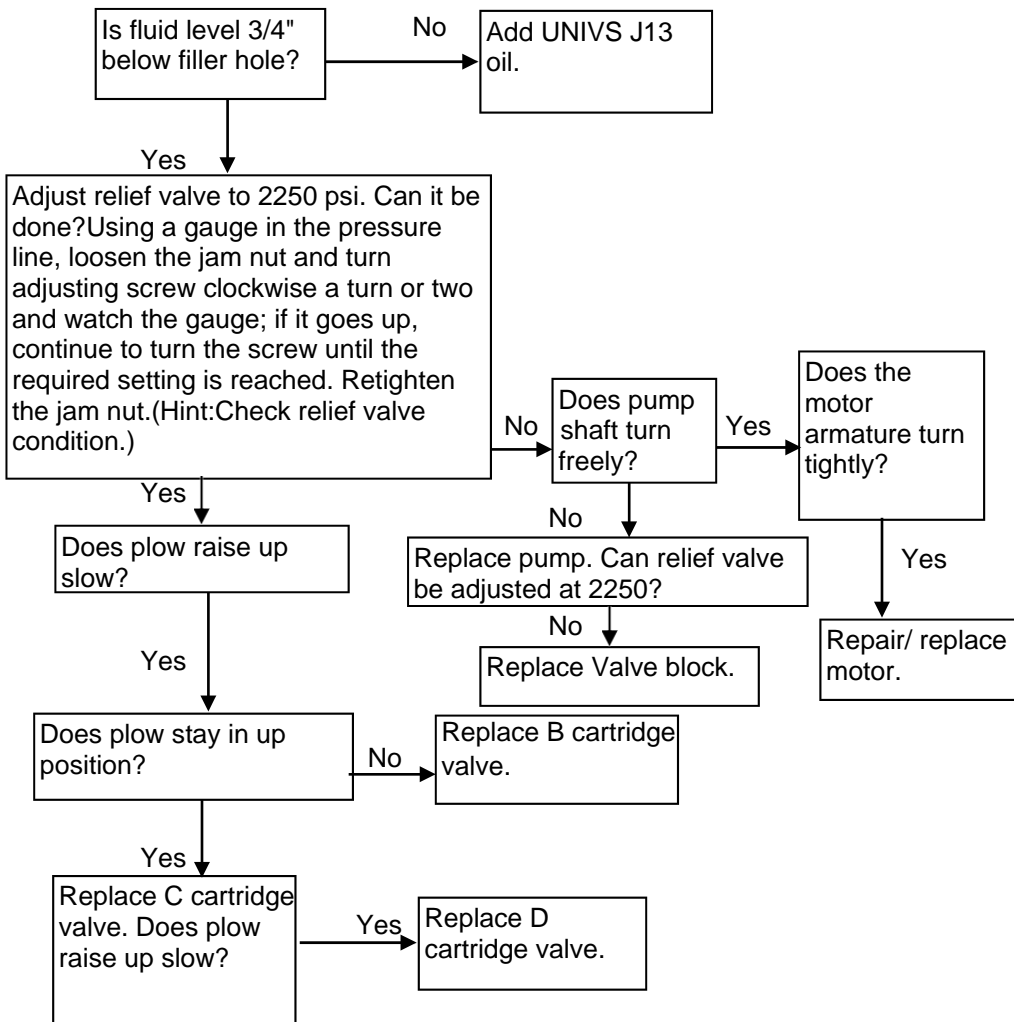

SNOW PLOW WILL NOT LOWER M673F (old version)

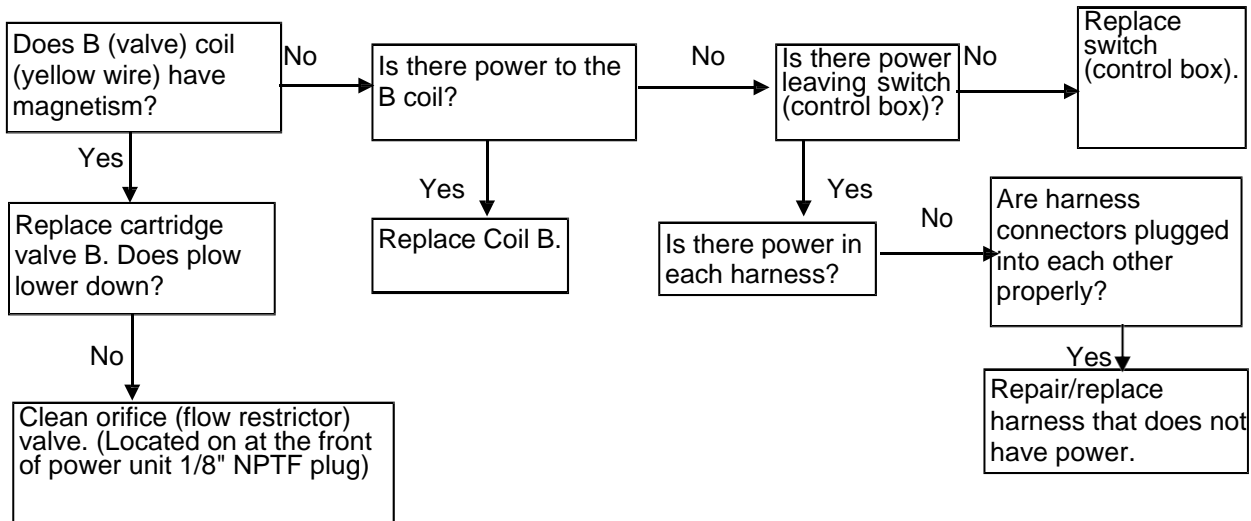

SNOW PLOW LEAKS DOWN M673F (old version)

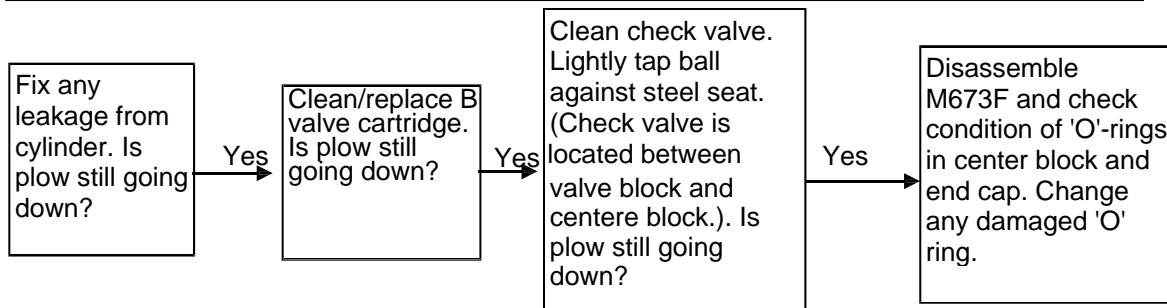

SNOW PLOW ANGLES BEFORE GOING UP (WHEN UP

If snow plow angles left before goes up change A cartridge valve.

SNOW PLOW WHEN IS FULLY ANGLED GOES UP (WHEN ANGLE SWITCH IS PRESSED) M673F (old version)

Change C valve cartridge.

SNOW PLOW DOES NOT ANGLE TO RIGHT SIDE M673F(old)

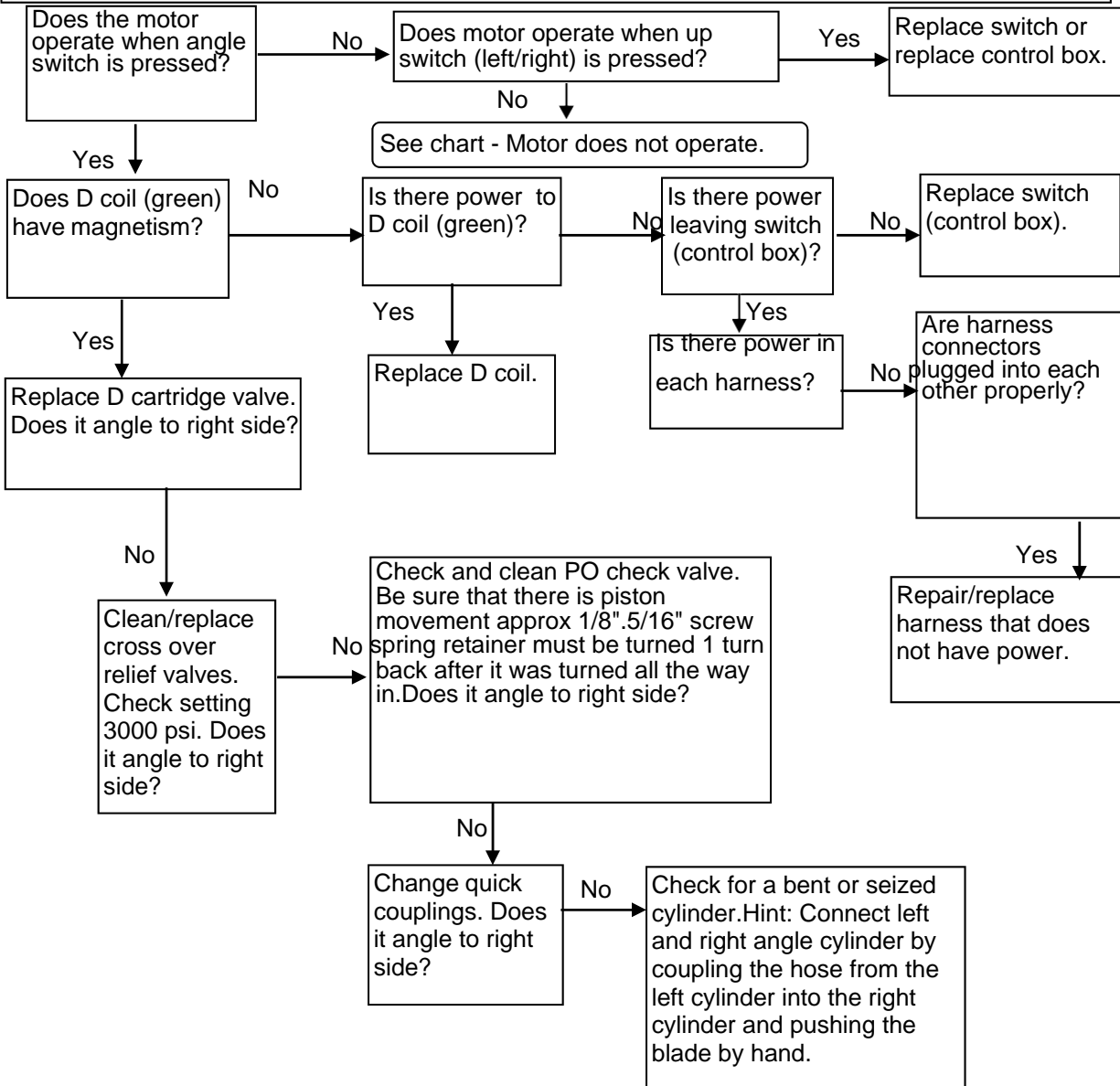

Note: Before start troubleshooting check that plow moves up and down. If plow does not move up and down see "plow does not raise".

SNOW PLOW DOES NOT ANGLE TO LEFT SIDE M673F(old version)

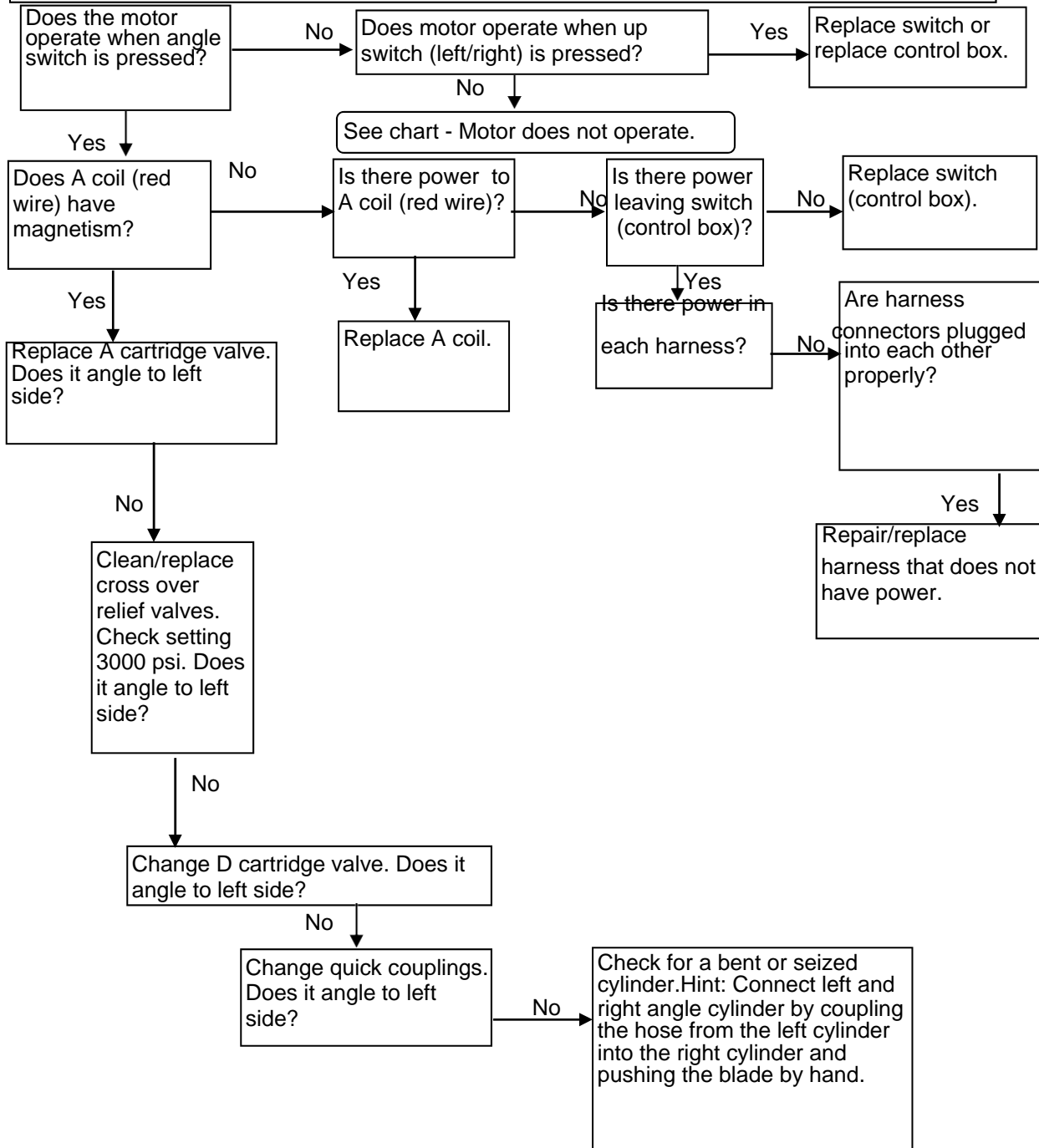

Note: Before start troubleshooting check that plow moves up and down. If plow does not move up and down see "plow does not raise".

PLOW DOES NOT HOLD ANGLE M673F(old version)

